



Parametric modelling environment (in Modelica) for buildings cluster simulation



Energy flexible building cluster modelling

Authors: Ilaria Vigna (EURAC); Marco Lovati (EURAC)
28/02/2019

www.energymatching.eu

Adaptable and adaptive RES envelope solutions to maximise energy harvesting and optimize EU building and district load matching



This project has received funding from the European Union's Horizon 2020 research and innovation programme under grant agreement N°768766

Table of contents

LIST OF TABLES.....	2
TABLE OF FIGURES.....	3
EXECUTIVE SUMMARY	4
1. INTRODUCTION	5
1.1 BACKGROUND, MOTIVATION AND SCOPE.....	5
1.2 WORKFLOW AND STRUCTURE	5
2. ENERGY FLEXIBLE BUILDING CLUSTERS	6
2.1 DEFINITION OF ENERGY FLEXIBILITY AND FORCING FACTORS	6
2.2 FIRST STEPS TOWARDS ENERGY FLEXIBILITY CONCEPT AT CLUSTER SCALE	6
2.3 DEFINITION OF MOST SIGNIFICANT ENERGY FLEXIBILITY INDICATORS AT CLUSTER SCALE.....	8
3. MODELLING ENVIRONMENT	9
3.1 MODELICA AND RC-NETWORK APPROACH	9
4. FIRST SIMPLIFIED VERSION OF THE BUILDING CLUSTER MODEL.....	10
4.1 NUMERICAL MODEL DESCRIPTION	10
4.2 SIMULATED BUILDING CLUSTER CONFIGURATIONS.....	12
4.3 PV SYSTEM MODELLING AND OPTIMIZATION	13
4.4 FIRST RESULTS.....	15
4.5 DISCUSSION.....	18
5. SECOND IMPROVED VERSION OF THE BUILDING CLUSTER MODEL.....	19
5.1 NUMERICAL MODEL DESCRIPTION	19
5.2 SIMULATED BUILDING CLUSTER CONFIGURATIONS.....	22
5.3 FLEXIBILITY ASSESSMENT	23
5.4 RESULTS AND DISCUSSION.....	24
6. CONCLUSIONS	29
7. REFERENCES	31
TECHNICAL REFERENCES.....	34

List of tables

Table 1: Reviewed indicators for energy flexible building cluster.....	9
Table 2: Geometrical and thermal properties of building typologies used in simulations.	13
Table 3: List of building cluster configurations analysed in simulations.	13
Table 4: Input used for the different cases of optimizations: the semi-column sign “;” represents different values of a stochastic variable.....	15
Table 5: Self production and peak capacity resulting from energy optimization and economic optimization	16



Table 6: Geometrical properties of the building typology used in simulations.23
 Table 7: Thermal properties of building components for different cluster configurations.23

Table of figures

Figure 1: List of forcing factors according to different levels of frequency6
 Figure 2: Model structure for each building of a cluster in Dymola environment.....12
 Figure 3: Monthly heating and cooling demand of the simulated cluster configurations.....16
 Figure 4: Energy optimization (left) and economic optimization (right) for BB Residential and BB Office cluster: monthly cumulative charts of electric demand covered by PV production and residual demand.....17
 Figure 5: Energy optimization (left) and economic optimization (right) for BB Mixed cluster – Results for a winter day (above) and a summer day (below).18
 Figure 6: Model of the building cluster integrated with thermal and electric grid in Dymola environment...19
 Figure 7: Reduced-order model of the structure of each building forming a cluster, using resistors and capacitors components of the library IDEAS.21
 Figure 8: Monthly renewable energy production from the cluster PV plant.22
 Figure 9: Monthly heating demand of the heavy weight (H) (top) and light weight (L) (bottom) simulated cluster configurations. Reference case (R) versus smart case (S).25
 Figure 10: Yearly heating demand of the heavy weight (H) (left) and light weight (L) (right) simulated cluster configurations. Reference case (R) versus smart case (S).26
 Figure 11: Daily trends for two representative days in January.....27
 Figure 12: Daily trends for two representative days in March.....28
 Figure 13: Monthly values of the Flexibility Index $FI_{RENEWABLES}$29
 Figure 14: Yearly values of the Flexibility Index $FI_{RENEWABLES}$ for the simulated cluster configurations.....29



Executive summary

This document reports a modelling environment development for the analysis of Energy flexible building clusters carried out within the EnergyMatching project. It deals with the definition of a cluster-tailored modelling strategy implemented in Modelica language aimed at integrating both building characteristics, RES availability and energy infrastructure features. Further developments and improvements of the models proposed positively contribute to perform simulations of building clusters in order to evaluate the impact of building technologies and cluster design strategies on RES harvesting maximization at building and district level. This research was accomplished in two main phases: (i) the design of a first simplified thermodynamic model of a cluster in Dymola environment, aimed at providing a building cluster energy demand as input for the EnergyMatching tool; (ii) the design of an improved thermodynamic model of a cluster specifically using the IDEAS library components, with the purpose to evaluate energy flexibility of a cluster of buildings and introduce a control strategy that actively manages the energy demand with the RES availability. The cluster archetypes results obtained from the first simulation runs, and shown in the following pages, can be included in the repository of the EnergyMatching hub as examples of district archetypes performances for Italian geoclusters.



1. Introduction

1.1 Background, motivation and scope

New generation of buildings are gradually moving from stand-alone consumers to interconnected prosumers (D'Angiolella, De Groote, & Fabbri, 2016) and the increasing interaction between buildings and grids requires an energy performance assessment at cluster scale, since neither the buildings nor the energy infrastructures can be fully analysed without considering their mutual connections.

The shift from building to cluster and district domain is strengthened by the European Commission, which in the “Clean Energy for all Europeans” legislative proposals (EC, 2016a) introduces the concept of Local Energy Communities (EC, 2016b) intended as new market players able to generate, consume, store and sell renewable energy.

As described in the EnergyMatching knowledge hub (Task 2.1), building clusters are an intermediate level which scale up to district level and can be defined as “groups of buildings interconnected to the same energy infrastructure, such that the energy behaviour of each building affects the energy performance of the whole system” (Vigna et al., 2018). At this scale, on the one hand, it is possible to detail the most important technological features of the buildings and, on the other hand, to consider the interactions within the energy grid. Therefore, the building cluster scale inherits many characteristics of urban infrastructure and can be identified as a suitable buffer for studying the complex energy interactions of urban energy systems at significantly reduced computational expense.

In current building design approaches, the exploitation of local RES by integrating related technology in building energy system rarely takes into account the mutual influences between building components (that influence the energy demand), renewable energy production and building interaction with electric or thermal grid. On the one hand, the grid perceives the building as a non-flexible object with specific features and fixed energy demand profile. On the other hand, the building is usually designed without considering the potential renewable energy profile production and the energy demand is a fixed input for sizing a posteriori (that is without an optimization) the technology exploiting RES. Furthermore, the building is usually conceived as a stand-alone entity, and the potential interaction with the surroundings is not considered.

The scope of this report lies in (1) the description of the modelling environment defined in Modelica for building cluster simulations and (2) the setup of control strategies to optimize energy matching through energy flexibility of building clusters.

The approach of this task scales the design from the single building level to the cluster level, by promoting an innovative modelling method aimed to support the definition of effective building technologies and cluster design strategies for maximizing the matching between locally produced energy and building energy consumption.

1.2 Workflow and structure

A cluster-tailored modelling strategy implemented in Modelica language was developed in order to integrate both building characteristics, RES availability and energy infrastructure features, balancing accuracy and number of inputs needed. In Dymola environment, a first simplified thermodynamic model of a building cluster was designed to familiarize with Modelica language and Modelica libraries' components and to provide a building cluster energy demand as input for the EnergyMatching tool; then, an improved thermodynamic model of a cluster was built using the IDEAS library components and a control strategy has been introduced to actively correlate the energy demand with the RES availability.



First, in Section 2, a literature review analysis has been conducted on *energy flexible building cluster* concept to establish a shared terminology and a list of key performance indicators, useful to define a common ground for definition and quantification of energy flexibility at cluster scale. Then, in Section 3, 4 and 5, a description and application of the two modelling approaches – simplified and improved thermodynamic models – are described and the main results in terms of energy performance, energy matching and energy flexibility performance are reported.

2. Energy flexible building clusters

2.1 Definition of energy flexibility and forcing factors

Energy Flexibility was defined as the capability of a building to react to one or more forcing factors, in order to minimize CO₂ emissions and maximize the use of Renewable Energy Sources (RES) (Vigna et al. 2018). The forcing factors represent a set of significant boundary conditions that could change during the lifetime of the entity considered (e.g. building, cluster or district) and have different levels of frequency, as shown in Figure 1:

– *Low frequency factors* (temporal fluctuations within the years-decades time range): climate change, macro-economic factors, technological improvement, building intended use and variation in the number of occupants, demographic changes (e.g. age, income);

– *High frequency factors* (temporal fluctuations within the minutes-hours time range): internal loads, solar loads, user behavior, energy prices.

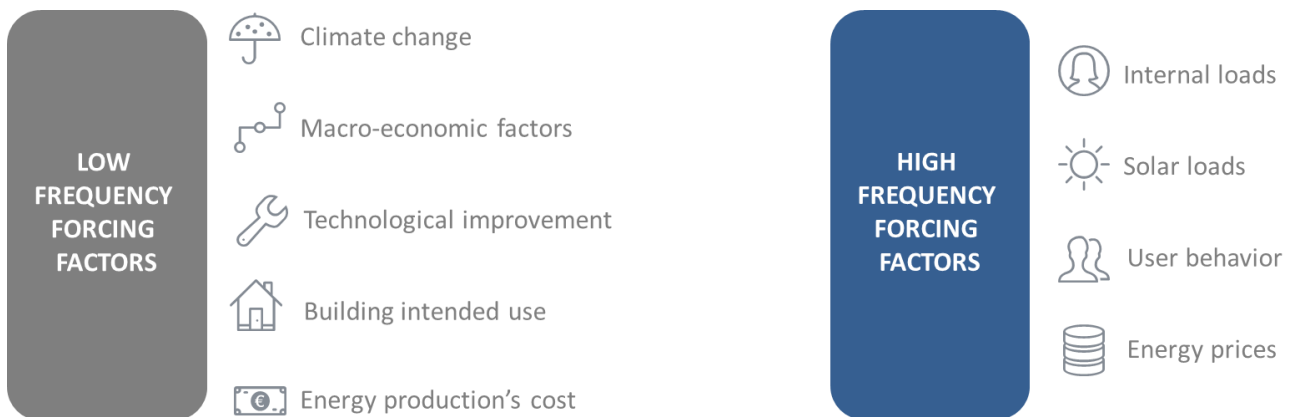

Figure 1: List of forcing factors according to different levels of frequency

2.2 First steps towards energy flexibility concept at cluster scale

Energy Flexible Building Clusters should demonstrate the capacity to react to one or more forcing factors in order to minimize CO₂ emissions and maximize the use of Renewable Energy Sources (RES).

Nevertheless, the absence of a consolidated definition requires as a starting point the analysis of some concepts used so far in the literature used to describe the synergy of energy efficient buildings and renewable energy utilization at an aggregated level. The concepts identified (Vigna et al., 2018) are the following:

Smart Building Cluster:

The concept of “Smart Building Cluster (SBC)” indicates “a group of neighbouring smart buildings electrically interconnected to the same micro-grid” (Ma et al., 2016). Considering the SBC scale, it is possible to obtain

an improvement of the local use of renewable energy, a decrease in the cost of electricity consumption, and a larger load shift in time due to different occupancy patterns and varying load profiles within a cluster composed of mixed-use buildings.

Zero Energy Neighborhood:

The “Zero Energy Building” concept still considers the individual buildings as autonomous entities and neglects the importance of reaching energy efficiency at a larger scale. In the future shift to NZEB 2.0 (D’Angiolella et al., 2016) the Zero Energy Neighborhood scale will take into account the numerous interactions between urban form, building energy needs and on-site production of RES (Marique & Reiter, 2014), in order to balance annual building energy consumption and individual transportation by the local production of renewable energy (Marique, Penders, & Reiter, 2013).

Micro Energy Hub:

In the framework of an Energy Flexible Building Cluster, buildings will increasingly interact with the energy systems and have the potential to take up an important role in the energy-supply-system stability by acting as micro energy hubs i.e. “multi hubs-generation systems, providing renewable energy production, storage and demand response” (Geidl et al., 2007). The key concept of the energy hub approach is the possibility to jointly manage the energy flows from multiple energy sources in order to improve the renewable energy sharing between different interconnected buildings (Darivianakis et al., 2015; Orehounig et al., 2014).

Virtual Power Plant:

It is possible to make an analogy between Energy Flexible Building Clusters and virtual power plants: in fact, Virtual Power Plants (VPP) are “collective generators of renewable energy sources that can store and adjust energy output on demand and at will” (Carr, 2011). An aggregator can group different distributed energy resource (DER) systems into a VPP in order to provide more Energy Flexibility than a single system and, in parallel, Energy Flexible buildings have the possibility to co-generate with current grids or operate solely to produce energy in a cost-effective way, while adapting/shifting the electricity consumption profile in time (De Coninck & Helsen, 2013).

Collaborative Consumption:

In the current market, end-users hold only the role of final consumers and are not involved in the energy supply side. The community engagement to reach a suitable energy management framework represents an opportunity to increase social acceptance of distributed generation in smart grids (Ahmadi et al., 2015). Collaborative consumption (CC) is “a social-based agreement framework”, in which different consumers cooperate to share their resources and to create valuable services for the benefit of the whole community (Belk, 2010). Therefore, an active participation of residents into the energy market improves their inclination towards cooperation in order to reschedule their consumptions and generate more renewable energy so as to minimize energy cost, carbon emissions and primary energy consumption (Dai et al., 2015).

Local Energy Community:

The European Commission proposal for a recast of the International Electricity Market Directive (EC, 2016b) establishes a framework for Local Energy Communities aimed at improving energy management at the community level and empowering local participants. In such a geographically confined network, all consumers can have a direct involvement in energy consumption, storage and/or the sale of self-generated



electricity to the market, and the up-take of new technologies and consumption patterns, including smart distribution grids and demand response, will get easier.

2.3 Definition of most significant energy flexibility indicators at cluster scale

Indicators are fundamental for quantifying the amount of Energy Flexibility that a building can offer, and measure how different aspects influence the sharing of renewable energies and the reduction of peaks of delivered energy demand in buildings. Indicators are also a way to effectively communicate the energy flexibility concept, providing a common language between energy players and supporting policy makers in the quantification of the actual impact of novel energy related policies.

A first literature review showed that the majority of existing indicators and approaches, related to Energy Flexibility quantification, just focus on single buildings. This report identifies a set of potential key performance indicators that could be adapted to the cluster scale and used to characterize Energy Flexible Building Clusters. The selected indicators have been classified into five different categories, as reported in Table 1:

1. The *Cost level* focuses on Energy Flexibility quantification with respect to costs.
2. The *Thermal level* includes indicators:
 - of Energy Flexibility related to the possibility to activate the envelope/ structural mass of the building;
 - referred to the Energy Flexibility that could be provided by controllable loads such as the consumed power of HVAC systems;
 - related to the thermal grid;
 - of thermal comfort related to the acceptance of indoor conditions by occupants (temperature fluctuations, air quality, etc.).
3. The *Electric level* comprises indicators referred to the measure of electric grid control over the demand and to the relation between on-site generation and load for a specific temporal resolution.
4. The *Thermal-electric level* encloses indicators related to cumulative energy demand/supply.
5. The *Other relevant indicators* section includes indicators related to other issues that influence the energy flexibility, such as the influence of the typological composition of a cluster on energy consumption and the readiness of a building to adapt its operation to the needs of the occupants and of the grid to improve its performance.



Table 1: Reviewed indicators for energy flexible building cluster.

Energy Flexible Building Cluster Indicators
Costs
Specific Cost of Flexibility (De Coninck & Helsen, 2013)
Spark Spread (Piacentino & Barbaro, 2013)
Total Supply Spread (Piacentino & Barbaro, 2013)
Flexibility Factor (Le Dréau & Heiselberg, 2016)
Thermal level
Available Storage Capacity (Reynders, 2015)
Comfort Index (Shen & Sun, 2016)
Electric level
Grid Control Level (Ahmadi et al., 2015)
Load Matching Index (Voss et al., 2010)
Grid Interaction Index (Voss et al., 2010)
Thermal-Electric level
On-site Energy Ratio (Ala-Juusela & Sepponen, 2014)
Annual Mismatch Ratio (Ala-Juusela & Sepponen, 2014)
Maximum Hourly Surplus (Ala-Juusela & Sepponen, 2014)
Maximum Hourly Deficit (Ala-Juusela & Sepponen, 2014)
Ratio of Peak Hourly Demand to Lowest Hourly Demand (Ala-Juusela & Sepponen, 2014)
Other relevant indicators
Homogeneity Index (Jafari-Marandi et al., 2016)
Smart-ready Built Environment Indicator (De Groote, Volt & Bean, 2017)

3. Modelling environment

3.1 Modelica and RC-network approach

The complex nature of the building cluster imposes the need for multi-domains modelling tools. In order to identify the most suitable tool for energy flexibility simulation at cluster scale, the selecting criteria considered were: (i) *interaction* (possibility to study the interaction between buildings and energy systems, including interconnection by thermal and electrical networks, the use of renewable energy systems and storage systems); (ii) *modelling scale* (opportunity to simulate a group of mixed-use buildings in just one model); *scalability* (possibility to model a cluster of buildings considering the proper detail related to both the two scales of project, from technological component and building envelope for single building to district plants and layouts at cluster scale); *balancing* (easy model construction, exchange and reuse). As results of this analysis and according to the review of Allegrini (Allegrini et al., 2015), Modelica has been identified as one of the proper holistic modelling language to address district-level energy system for evaluating the whole potential of sharing/exchange energy between interconnected buildings.

Modelica is an equation-based object-oriented modelling language able to decompose complex physical systems into structured hierarchies of elementary components (Fritzson, 2004). Modelica adopts an acausal modelling approach (Elmqvist & Mattsson, 1997) and the physical construction of the model is enhanced by a graphical interface (Elsheikh, Widl, & Palensky, 2012). The advantages that the employment of Modelica brings are the multidisciplinary modelling using standardized libraries (<http://www.iea-annex60.org/>) and the support of fast prototyping of physical models by encouraging the implementation of reusable, independent and extensible components.



A detailed physical model of a building cluster requires consistent computational resources to perform both the simulation and the optimization (Lauster et al., 2014). To overcome this issue, model simplification techniques, such as resistance-capacitance (RC) networks, seem promising since they represent a good compromise between reasonable accuracy, parameters requirement and computational effort (Kämpf & Robinson, 2007). The electric analogy of RC networks has been extensively used in literature, representing the conductivity of materials as electric resistance and the thermal mass as electrical capacity (Achterbosch et al., 1985; Fraisse et al., 2002; Kämpf & Robinson, 2007; Nielsen, 2005; Ramallo-González, Eames, & Coley, 2013).

Moreover, many authors have made use of the electric analogy in Modelica language to represent heat transfer in a building cluster. Lauster (Lauster et al., 2015) describes a low order thermal network model for multiple buildings using Modelica AixLib (Müller et al., 2016). The number of RC elements for wall has been varied in order to test dynamic behaviour of components and related calculation times. The building envelope model proposed by Burhenne (Burhenne et al., 2013) is also based on equivalent circuit model made of resistors and capacitors using components of Modelica Standard Library (MSL) (<https://github.com/modelica/Modelica>). The Buildings Library developed at LBNL (Wetter, 2009) has been used to predict HVAC load dynamic of building districts by He (He et al., 2015). The Integrated District Energy Assessment by Simulation (IDEAS) library (Baetens et al., 2015; Van Roy, Verbruggen, & Driesen, 2013) has been applied by Reynders (Reynders, Diriken, & Saelens, 2014) with the aim to identify suitable RC models for whole set of dwellings.

According to this brief review, in this work a simplified model for building clusters has been adopted, based on RC-elements and Modelica libraries' components, in order to properly describe the features and the energy performance of the cluster and the building interactions with the grid.

4. First simplified version of the building cluster model

4.1 Numerical model description

To analyze the energy demand at cluster scale, a first simplified thermodynamic model of a cluster in Dymola environment (Dassault Systèmes) has been defined through resistors-capacitors and Modelica Standard Library components (Figure 2). In this first simplified version of the model, some aspects have not been included, for example the DHW and de-humidification loads. The following sections report a description of the main items included in the model.

Boundary conditions

The weather data are referred to the climate of Bolzano, Italy, and have been obtained from Meteonorm (www.meteonorm.com).

Building envelope

The materials and the properties used for building envelope components are based on the Italian standard UNI/TS 11300-1 (2014). The thermal behaviour of each building envelope was simplified as an equivalent electrical circuit of resistances and capacities, in order to reduce computational resources used and parameters required. As thermal network model, the One Element Model has been adopted (Lauster et al., 2015): all the thermal masses were merged into one substitutional capacitance connected via resistances to the ambient and indoor air. The thermal capacity C represents the thermal mass of walls and it is expressed as in (1):



$$C = A \cdot s \cdot cp \cdot \rho \text{ [J/K]} \quad (1)$$

where A indicating the surface area of the envelope in m^2 , s the thickness of the walls in m , ρ is the density of the walls in kg/m^3 and cp the specific heat capacity in J/kgK .

Being this an RC model, the thermal resistance of the wall is expressed as an actual resistance and not as a transmittance (as usually expressed in literature). The thermal resistor $R1$ was used to represent the convective heat transfer between the envelope surface and the inner air of the zone and it is expressed as in (2):

$$R_1 = \frac{1}{h \cdot A} \text{ [K/W]} \quad (2)$$

where h indicating the convective heat transfer coefficient in $\text{W/m}^2\text{K}$ and A is the heat transfer area of the envelope.

The thermal resistors $R2-4$ represent the resistances of envelope walls, ceilings and windows, respectively, with the outdoor air of the building and they are formulated as in (3) and connected to the exterior temperature boundary condition:

$$R_{2-4} = \frac{s}{A \cdot \lambda} \text{ [K/W]} \quad (3)$$

where s indicating the thickness of each envelope component in m , A the surface area of the components and λ the thermal conductivity of the envelope components in W/mK .

Building windows

The solar gains as well as the daylighting was determined by means of DAYSIM coupled with Modelica through a Python interface. The irradiation on the building surfaces was defined for every hour of the year as an external parameter considering the effect of external shadings and obstacles. The internal gains were calculated according to the area and solar heat gain coefficient of the windows.

Soil

The soil was represented as a single layer heat conductive component.

Air model

The air component was connected to the thermal resistor for convective heat transfer between the capacitor and the inner air of the building zone. The Medium parameter contains information about the type of fluid and its properties.

Ventilation

The ventilation system was simplified as a resistance component and the airflow rates assumed are based on Italian national standard (CEN, 2007).

Heating and cooling model

Heating and cooling is provided by electrically driven heat pumps described with power parameters and their behaviours were considered as ideal: in fact, they can remove or add energy to the heat capacity component of the zone. Two simplified controllers enable the heater and the cooling system in order to keep the air temperature in the comfort range. The coefficient of performance (COP) was assumed as constant on an average value of 3.



Occupancy, appliances and lighting

Reference residential occupancy schedules have been defined and imported according to prEN16798-1 and ISO/FDIS 17772-1 standards (Ahmed et al., 2017) as a matrix into the model, in order to define heat flow from occupants, appliances and lighting.

District heating

A simplified district heating system was introduced in order to allow energy exchange between buildings in the cluster. Thanks to a shared thermal capacitor connected to the common heat generator, the thermal demand of the buildings can be aggregated. The consumptions were assumed as fully electric and the district heating system was represented as a thermal capacitor connected from one side to a heat exchanger and on the other side to the heating system of each building of the cluster.

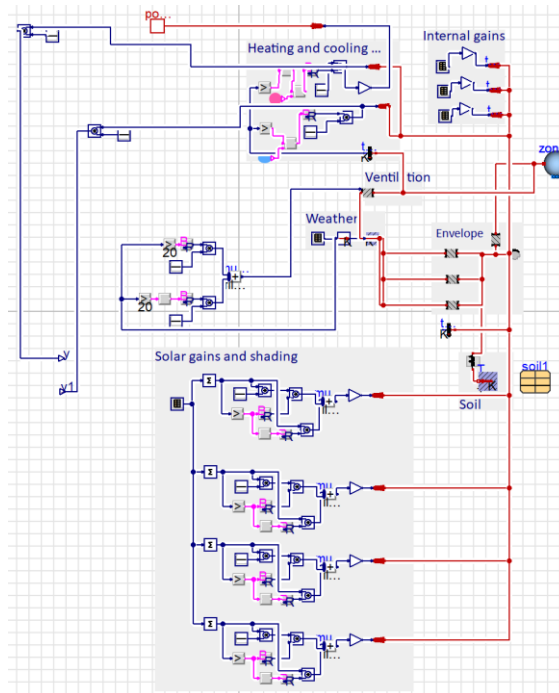

Figure 2: Model structure for each building of a cluster in Dymola environment.

4.2 Simulated building cluster configurations

The simulation of different cluster configurations (composition: single family house/building block; use: residential/office/mixed) provided different energy demand profiles as input for the sizing and configuration of PV field, designed by means of energy-matching-based optimization. The varying parameters of composition and use were selected among the main parameters affecting energy characteristics in a building cluster identified in the EnergyMatching knowledge hub.

Moreover, as a general hypothesis for the calculations, the overall energy demand was considered as fully supplied by electricity from the grid, and the RES production was provided by PV. The next sections describe the cluster configurations that were analyzed and give an overview of the simulation model structured in Modelica language and of the optimization strategy adopted for PV system integration.

The buildings used for the cluster composition were based on Italian building stock typologies presented in TABULA project (webtool.building-typology.eu). In this phase, the shape of buildings was oversimplified because the focus was on the methodological approach for numerical modelling and optimization.





The building typologies simulated are the typical Italian Single Family House (SFH) and Building Block (BB) defined for the construction period after 2006. The choice of typologies was made to assess the performance of the EnergyMatching Strategy in two antipodal examples (antipodal within the regular residential urban fabric). According to descriptions reported in TABULA (Corrado et al., 2011), the main geometrical and thermal properties of these typologies are summarized in Table 2.

Four different cluster configurations were defined, in order to analyse the influence of building characteristics and use on the overall energy demand profile. Four buildings formed each building cluster and the definition of the configurations relied on the variation of two parameters: the building typology (SFH and BB) and the building use (Residential, Office, Mixed). Table 3 reports the list of the four cluster configurations.

Table 2: Geometrical and thermal properties of building typologies used in simulations.

Single Family House SFH		
Volume	607 m ³	
Gross heated area	174 m ²	
Component	A [m ²]	U [W/m ² K]
Exterior wall	223.3	0.34
Ground slab	96.4	0.33
Roof	96.4	0.28
Window area	21.7	2.2
Building Block BB		
Volume	8199 m ³	
Gross heated area	2124 m ²	
Component	A [m ²]	U [W/m ² K]
Exterior wall	1696.9	0.34
Ground slab	371	0.33
Roof	371	0.28
Window	270	2.2

Table 3: List of building cluster configurations analysed in simulations.

Configuration 1			
Building typology	SFH		
Use	Residential		
Configuration 2			
Building typology	BB		
Use	Residential		
Configuration 3			
Building typology	BB		
Use	Office		
Configuration 4			
Building typology	BB		
Use	Mixed 75% Residential		

4.3 PV system modelling and optimization

For the PV system optimization, the EnergyMatching tool was used, developed in the framework of the task 2.2 of the EnergyMatching project. Unlike most photovoltaic design software, this tool does not require the capacity and positions of the PV system as an input for the simulation (Lovati et al., 2018). This might integrate

usefully in the architectural design workflow where the PV position and capacity can become a creative constraint alongside other building components such as structures, windows and HVAC systems.

Inputs for the EnergyMatching tool

The tool required a cloud of points describing the building geometry and an irradiation matrix in order to express the irradiation in W/m² for every hour of the year, and for each building unit surface. Every point represented a solar collector with a given area and is associated with an hourly irradiation.

Aside from these inputs, Table 4 reports the set of techno-economic parameters required for the building clusters simulation. Following the purpose of matching energy demand and production with the optimization, as a general hypothesis, no electricity revenues from the grid were assumed and, consequently, the electricity that was not instantaneously consumed was given to the grid for free.

PV modelling

The PV systems were modelled in a simple way to ensure fast computing speed and reducing the effort for collecting model inputs in the early design stage. The power profile of the PV system depended on the irradiation falling on the module and on the operating cell temperature (Maturi et al., 2014), while aspects such as soiling or AC-DC losses were assumed as part of a static performance ratio coefficient of 0.8. The performance ratio (PR) was defined as the ratio between the system yield (energy produced in time period over the nominal power) and a reference yield (the incident solar energy in time period t over the reference irradiance 1000 W/m²).

Optimization algorithm and fitness functions

The optimization algorithm used by the EnergyMatching tool for this study was the One-By-One (OBO), characterised by an additional (incremental) behaviour: the optimization algorithm started with an empty system (no PV is present) and added the most profitable PV collectors one by one until it reached the maximum value of the fitness function. The fitness functions that the algorithm could maximize were the following: Net Present Value (NPV) function and Lifetime Cumulative Electricity Production (LCEP) function of the system at the 25th year after installation.

The formula of NPV calculation is expressed as in (4):

$$NPV = \sum_{t=0}^N \left(\frac{c \cdot P_c + s \cdot P_s - \omega_{PV} \cdot C_t}{(1+i)^t} \right) - \omega_{PV} \cdot C_0 \quad (4)$$

where N is the time horizon for the simulation (i.e. 25 year), t is the year of operation and c is the annual cumulative energy produced and consumed onsite (instantaneously or thanks to the battery). P_c and P_s are the cost of electricity and the revenues from the grid (i.e. 0.2 and 0 €/kWh respectively), S is the annual cumulative energy produced and sold to the grid, i is the discount rate, ω_{PV} is the capacity of the PV system and C_t is the cost for maintenance [€/kWp]. Outside of the sum, there is the initial cost for the component, where C_0 expresses the unitary costs for PV. In this study, there were no batteries for electric storage, to keep the focus on the hourly interaction between the local production system and the cluster energy demand.

The formula of LCEP calculation is expressed as in (5):

$$LCEP = \sum_{t=0}^N (c) - \omega_{PV} \cdot C_{E0} \quad (5)$$

where the embedded energy $\omega_{PV} \cdot C_{E0}$ (C_{E0} represents the initial unitary energy cost of construction of the PV system in MWh/kWp) is subtracted from the lifetime cumulative sum of the energy instantaneously consumed c .



As it is evident from Equations (4) and (5), both NPV and LCEP are influenced by the capacity and positioning of the PV system; for that reason these variables can be manipulated by the optimization algorithm for searching the maximum economical value or best energy balance in the lifetime.

Table 4: Input used for the different cases of optimizations: the semi-column sign “;” represents different values of a stochastic variable.

Efficiency	Electricity price P_c	Electricity revenues P_s
16,5%	0.2 €/kWh	0 €/kWh
Cost of PV C_0	Unitary Embodied energy of PV C_{E0}	PV degradation
1800 €/kWp	5.56 MWh/kWp	0.3;0.8 % year
Load growth	Electricity price growth	Electricity revenues growth
0;2 % year	-2;2 % year	0 % year
Discount rate i	Maintenance costs C_t	
0	18;36 €/kWp year	

Output

The output consisted in a cloud of selected points, representing the building unit surface. The EnergyMatching tool in fact suggested how many PV modules should be installed and in which positions (as a sub-system of the cloud of points given as input), according to an energy optimization (maximization of the LCEP function) or economic optimization (maximization of the NPV function).

4.4 First results

Heating and cooling demand

The monthly heating and cooling demand of the four cluster configurations are reported in Figure 3.

For all the configurations, heating and cooling seasons are clearly divided and without significant overlapping. It is evident the diversity of scale and time of energy demand for the different clusters, due to the variation of both building typologies (volume, surface area of envelope components, number of floors) and use (occupancy schedules and heating and cooling systems operation).

Considering the climatic boundary conditions of the city of Bolzano, Italy, it is possible to observe that for residential use, both SFH and BB typology show a higher monthly energy demand for heating than for cooling. Particularly the highest values of heating demand occurred for the SFH configuration (almost 30 kWh/m² during the month of January).

Between the configurations with BB typology, configuration 3 with office use reports the highest values of cooling demand (almost 11 kWh/m² during the month of July).

The resulting energy demand profiles were used as inputs for the energy and economic optimization, in order to compare the different configurations and figure out which cluster typologies favored the energy matching.



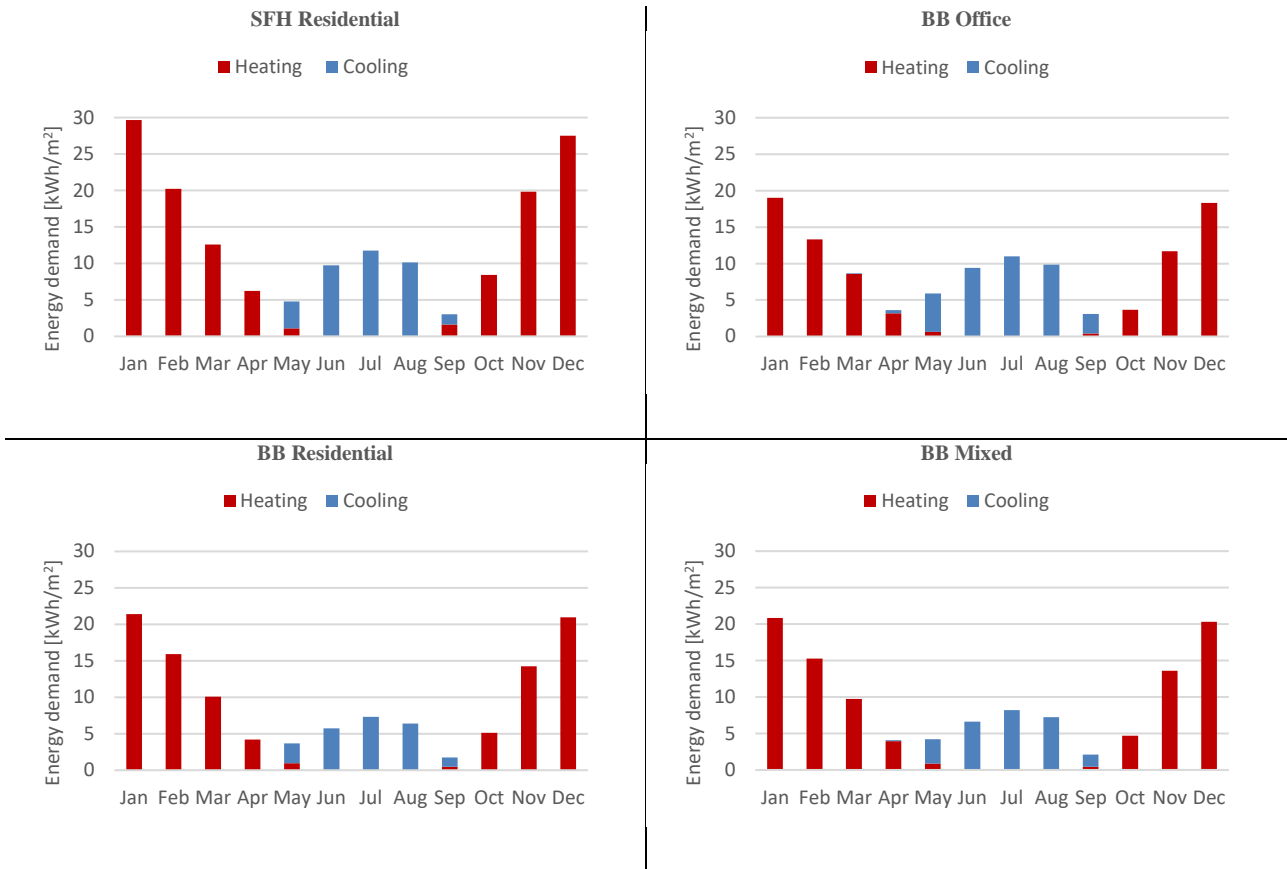

Figure 3: Monthly heating and cooling demand of the simulated cluster configurations.

Energy and economic optimization

The results of energy and economic optimization for the PV integration are reported in Table 5:

- the self production represented the percentage of electric demand that was instantaneously covered by the PV production over a period t;
- the peak capacity referred to the size of the PV system, expressed in kW of power output at standard test conditions (cell temperature of 25°C, irradiance of 1000 W/m² and air mass 1.5 “AM1.5” spectrum).

Table 5: Self production and peak capacity resulting from energy optimization and economic optimization.

	Energy optimization		Economic optimization	
	Self production [%]	PV peak capacity [kWp]	Self production [%]	PV peak capacity [kWp]
SFH Residential	33.2	5.70	10.7	1.19
BB Residential	28.9	40.39	14	13.78
BB Office	39.2	59.88	9.7	9.7
BB Mixed	32.7	45.86	16.9	16.63



Looking at the results obtained by optimizing LCEP (energy optimization), it is possible to notice that all the configurations gave a load coverage of around 30%, due to the use of PV-produced energy, while the configuration with office use registered the best performance with a coverage of 39.2%. Considering the optimization of NPV (economic optimization), the BB Residential and BB Mixed configurations reached the highest energy matching and yearly load coverage, respectively of 14 and 16.9%. Therefore, the BB Office configuration results were the best from the point of view of energy optimization and the worst considering the economic optimization. We need to highlight again that in both economic and energy optimization there was no revenue from the energy fed into the grid.

The monthly cumulative charts of electric demand covered by PV production and residual demand (both in MWh) for BB Residential and Office are reported in Figure 4. The monthly values were derived from hourly values and the coverage of the electric demand referred to a contemporary match with the production.

The results of the LCEP optimization (Figure 4, left) show that the capacity of the optimal PV system was not limited by the over-production but by the availability of the electric demand. In other words, the system could afford to put large amounts of electricity into the grid (which accounts as energy lost in the algorithm) as long as there were hours with residual electric demand. The cumulative electric demand of the BB Office cluster was higher compared to the BB Residential cluster – especially due to the significant cooling demand required by the office function– and this determined an increase of peak capacity and consequently a higher load reduction potential.

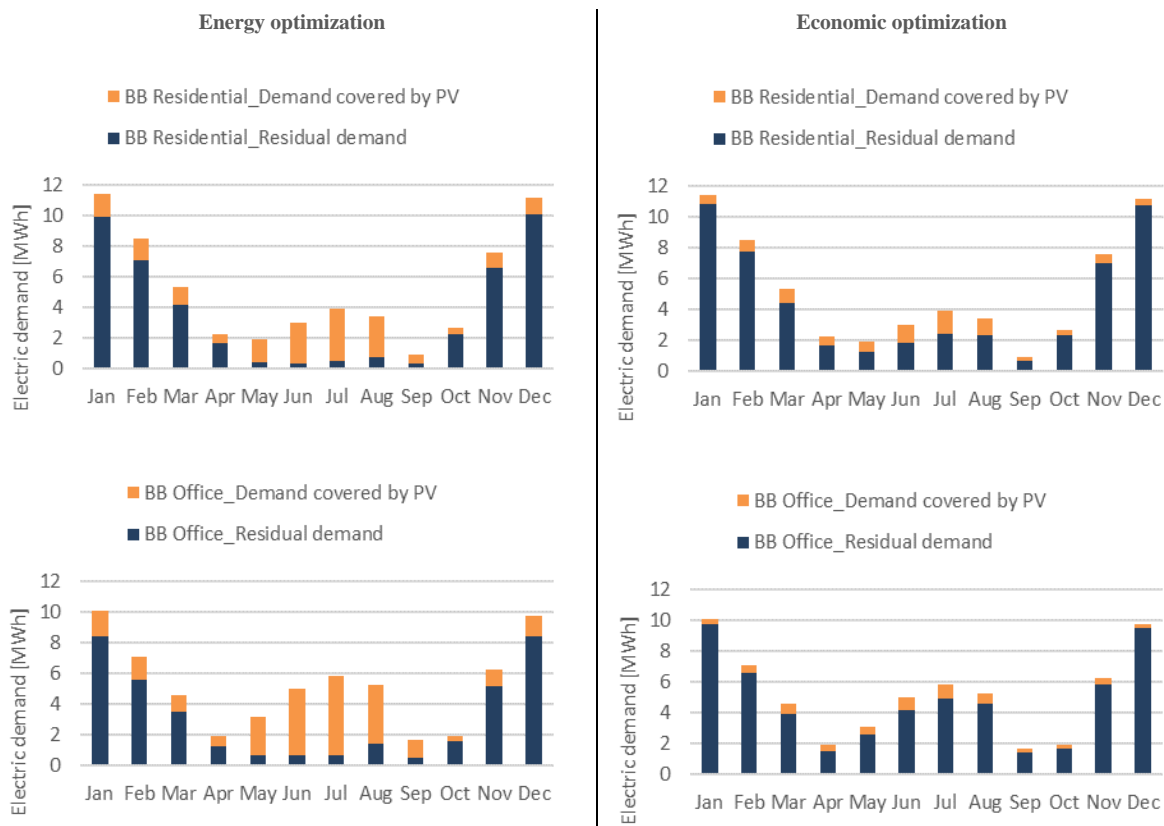

Figure 4: Energy optimization (left) and economic optimization (right) for BB Residential and BB Office cluster: monthly cumulative charts of electric demand covered by PV production and residual demand.

The economic optimization (Figure 4, right), on the other hand, selected a significantly smaller system because the economic cost of PV (€/kWp) was high relatively to its embedded energy cost (mWh/kWp). This relative expensiveness made the system un-economical when some energy was sent to the grid, forcing the algorithm to select a smaller system even if there were large reservoirs of unmet demand. For both BB Residential and Office configurations, it is evident that the demand covered by PV is low during the winter

season. To overcome this limit and improve the energy matching, some possible strategies that should be considered in further developments are the design of accurate control strategies and the potential contribution from thermal and/or electric storage technologies.

The daily results of the BB Mixed cluster optimization, referred to energy optimization and economic optimization are reported in Figure 5. During the winter day, for both the economic and the energy optimization, the PV started producing when most of the load turned off, with a coverage of 10.9% and 17.8% respectively. The energy-optimized system was affected by a strong overproduction. On the contrary, during the summer day, the PV production covered the electric demand of 35.4% in the economic optimization and of 92.3% in the energy optimization.

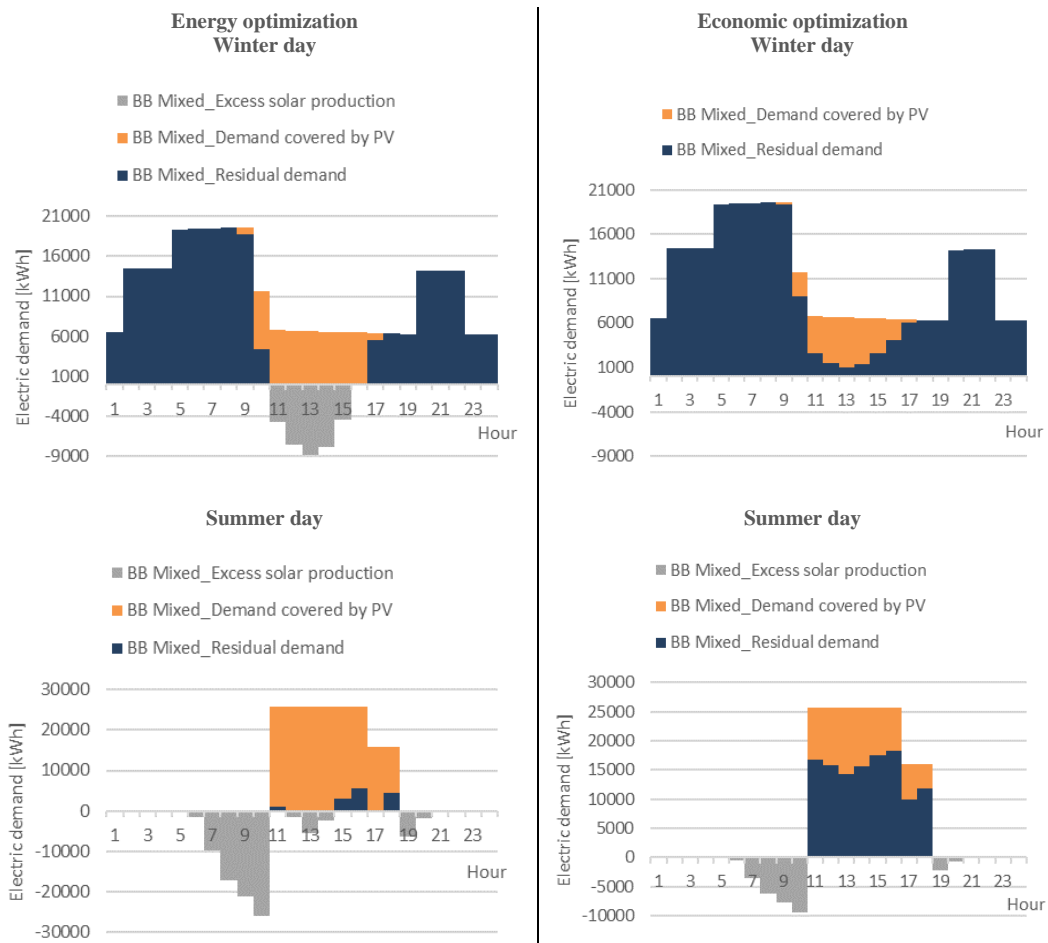

Figure 5: Energy optimization (left) and economic optimization (right) for BB Mixed cluster – Results for a winter day (above) and a summer day (below).

4.5 Discussion

Before the discussion, it is important to underline that the following results are referred to the HVAC load alone, obviously the inclusion of other electric loads would improve the outcomes in terms of installed capacity, self-production and economic benefit. This first study provided the results of the optimization of the PV installation in four diverse cluster configurations, which presented different building use and geometry. Comparing the energy demand and the production of the optimized PV system, between 10% (for the economic optimization) and 40% (for the energy optimization) could be covered by PV without electric storage.



There was a strong variation of the optimization results if economic (NPV) or lifetime cumulative energy fitness function (LCEP) were considered, and this was especially evident for the case of the BB Office cluster. These two functions are equally focused on maximizing the electricity self-consumed, but they lead to a dramatically different behaviour due to the constraints that they exert on the system. The economic optimization had a much smaller margin of earnings compared to the energy one and thus its main limit seemed to be the over-production. In fact, the system cannot afford to over produce too often along the year (also due to the lack of revenue from the grid) and its size (9.7 to 16.63 kWp for all the BB clusters) was therefore limited despite the presence of significant reservoirs of electricity demand. The energy optimization, on the other hand, had a huge margin of earnings and could afford to over-produce for a significant time along the year. This flexibility lead it to introduce larger systems (40.39 to 59.88 kWp for all the BB clusters) to cover the potential electricity demand until it was over, despite an important over-production.

This first research effort introduced a preliminary approach for modelling buildings cluster and related energy infrastructure, enabling to assess the influence of cluster characteristics (composition and use) both on energy demand and energy matching with local PV production. In following developments, additional analysis were performed and further cluster features (i.e. thermal mass and control strategies) were taken into account, in order to evaluate the impact of different building characteristics on the maximization of RES use at cluster scale.

5. Second improved version of the building cluster model

5.1 Numerical model description

To simulate the interaction between buildings and energy grid, a second improved thermodynamic model of the cluster integrated with the energy grids, shown in Figure 6, was defined using the Modelica model environment for Integrated District Energy Assessment Simulations (IDEAS) with Dymola interface (Dassault Systèmes).

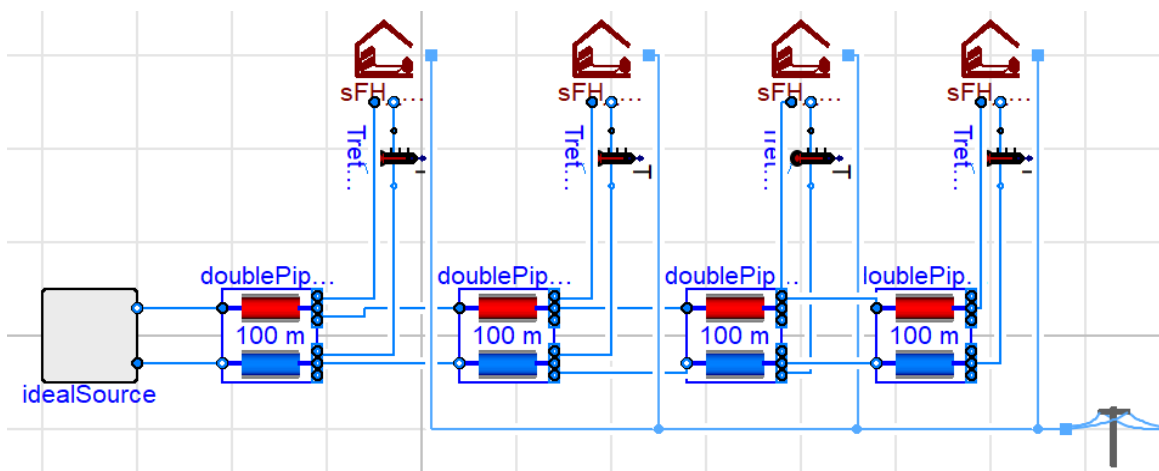

Figure 6: Model of the building cluster integrated with thermal and electric grid in Dymola environment.

The building cluster models were set out following a series of structured methodological steps reported in the following subsections.



Translation of geometrical and thermal properties of buildings in Modelica language

To automatically generate the reduced-order models, the open-source Python package TEASER (Remmen et al., 2017) was employed, although in a slightly adapted version. The original version of TEASER imports a CityGML model, containing the building geometry, construction year, the number of floors and their height as well as the building height, enriches these data with material layers for all building elements based on the German TABULA project and exports Aixlib or IBPSA Modelica models. For this work, as no CityGML model of the buildings was available, an additional import feature was implemented in TEASER, in particular import from a csv-file. The csv-file contained the same data as required for the CityGML file, but considered only 8 possible orientations for the building elements (N, NE, E, SE, S, SW, W and NW) (De Jaeger et al. 2018) and only one tilt for all the pitched roof parts of a particular building. Additionally, the German data, used for the data enrichment, were replaced by Italian data. Finally, the export of IBPSA reduced-order models to the IDEAS Modelica library (Jorissen et al., 2018) was implemented.

Definition of the building cluster numerical model in Dymola environment

The IBPSA reduced-order model for the thermal zone is included in the IDEAS building model. The cluster was modelled in IDEAS library and simulations were performed in Dymola environment. The IDEAS-Integrated District Energy Assessment Simulations (<https://github.com/open-ideas/IDEAS>) library allows simultaneous transient simulation of thermal and electrical systems at both building and feeder level. The main items included in the model are described below.

- Boundary conditions

The weather data conditions were referred to the city of Bolzano, Italy. A Typical Meteorological Year (TMY) file was obtained from the Meteonorm database (www.meteonorm.com).

- Building envelope

To reduce computational effort and keep an adequate level of accuracy, the building envelope was described through a Reduced-Order Model (ROM), shown in Figure 7. The distributed thermal mass of building envelope components was defined as a model of RC network analogue to electric circuits, as described in Lauster et al. (2014). The thermal masses of each building envelope component (external walls, ground slab, roof and internal walls) were represented as a vector of capacitances. Solar gains, internal gains and heating were distributed over the capacities. Additionally, for each envelope component a vector of resistances was defined, representing the radiative heat transfer between building components and the convective heat transfer between building components and both the outdoor and the inner air of the zone. All the values of the resistances and capacitances were automatically calculated within TEASER, before generating the IDEAS building models.

Based on the archetypes of Italian building stock presented in the TABULA database (webtool.building-typology.eu), the geometrical and thermal properties of the selected buildings were translated into reduced-order Modelica models using the Python package TEASER developed by RWTH Aachen (Remmen et al., 2018).

The simulation of different cluster configurations was performed to obtain different energy demand profiles at cluster scale and then evaluation of the impact of building thermal mass level on cluster energy demand and energy flexibility.



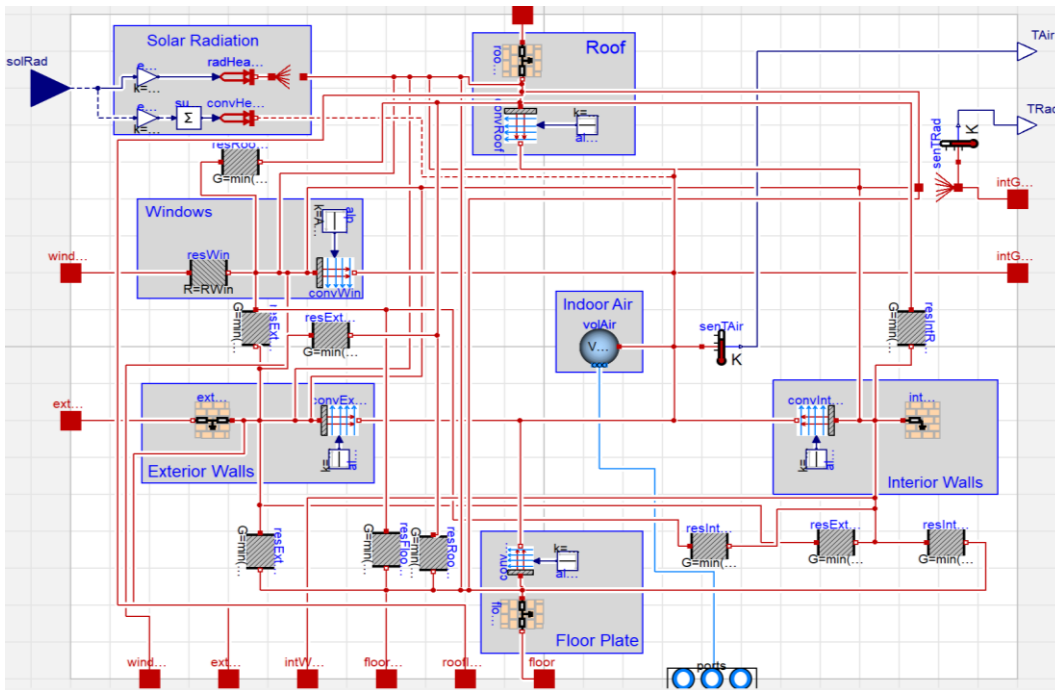

Figure 7: Reduced-order model of the structure of each building forming a cluster, using resistors and capacitors components of the library IDEAS.

- Systems

The buildings were equipped with radiators as heat emission system, connected to the district heating network through a heat exchanger. As the focus of this work is on the heating period, no cooling system was included. The domestic hot water circuit was modelled as a hot water storage system. The mechanical ventilation system was set with a constant ventilation rate of 0.5 1/h, with recuperation efficiency of 84%.

- Occupancy and appliances

The residential occupancy and appliances use profiles were stochastically defined using the Load Profile Generator tool (<https://www.loadprofilegenerator.de/>). Four different load profiles were created:

- Profile #1: Family consisting of 2 adults (both workers) and 3 children;
- Profile #2: Couple of adults (1 worker);
- Profile #3: Family consisting of 1 adult woman (worker) and 2 children;
- Profile #4: Single adult man (worker).

The stochastic data referred to heat flows from occupants and appliances have been imported in the model as a matrix. The temperature set-points were not influenced by the stochastic occupant behaviour, as they were specifically designed and used as inputs, as described in the *Flexibility assessment* section.

- District heating

The district heating network was represented through a succession of distribution double pipe models (van der Heijde et al., 2017), supplied by an ideal source. For the purpose of this analysis, aimed to implement the methodology to evaluate the flexibility of clusters correlating the heating energy demand to the PV production as a forcing factor, we adopted as an ideal source, a large-scale heat pump electrically driven. This technological system is in line with the limited size of the cluster and with proven experiences across Europe of large scale heat pumps (<https://www.ehpa.org/fileadmin/red/03. Media/03.02 Studies and reports/Large heat pumps in Europe MDN II final4 small.pdf>, <http://www.cool-dh.eu/demo-sites-and-innovations-in-cool-dh/osterby-hoje-taastrup/>).



Definition of the renewable energy production profile of the local installed cluster PV system

The PV design software EnergyMatching tool – developed in the framework of Task 2.2. of EnergyMatching – was used to define a reference PV system capacity and solar collectors' position for the cluster according to an energy optimization, as described in Section 4.3 (Vigna et al., 2018b; Lovati et al., 2018). The resulting renewable energy production profile served as a forcing factor (i.e. an external signal to which the building cluster was supposed to react) for the energy flexibility assessment of the cluster, as explained below. The monthly values of the production from the PV plant are reported in Figure 8. The PV capacity installed in the cluster was of 14.33 kWp. The modules dimensions were 1.989x1.63 m, the static performance ratio coefficient was of 0.8 and the efficiency assumed was of 17%.

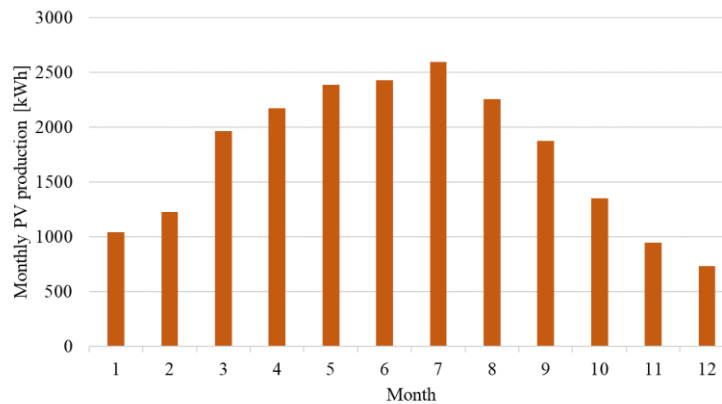

Figure 8: Monthly renewable energy production from the cluster PV plant.

5.2 Simulated building cluster configurations

The buildings adopted for this study are referred to the archetypes presented in the IEE-Project TABULA database for the Italian building stock typology of the detached Single Family House (SFH) (Corrado et al., 2011) of the construction period after 2006. Such construction period has been selected with the aim to investigate the flexibility performance of new buildings (nZEB) with local integrated renewable energy sources.

The geometrical properties of the building typology used in simulations are summarised in Table 6.

As assumption, the internal walls and floor had the same surface area as respectively the outer walls and the ground floor. The thermal transmittance values of the building envelope components were set accordingly to NZEB Italian requirements defined in D.M. 26.06.2015 (Decreto del Ministero dello Sviluppo Economico, 2015): U -value of 0.22 W/m²K for the opaque elements (exterior walls, ground slab, roof) and U -value of 1.1 W/m²K for the transparent elements.

The building components' thermal mass, identified in the EnergyMatching knowledge hub as one of the main parameters affecting energy characteristics in a building cluster, was selected as varying parameter, to investigate its impact on cluster energy and flexibility performance. For the exterior walls, roof, internal walls and internal floor, two different levels of thermal mass -heavy (H) and light (L)-, respectively referred to two different structural cores (concrete and laminated timber) were considered. The main thermal properties are reported in Table 7.



Table 6: Geometrical properties of the building typology used in simulations.

Single Family House SFH	
Volume	607 m ³
Gross heated area	174 m ²
Number of floors	2
Component area	
Exterior walls	225.3 m ²
Ground slab	96.4 m ²
Roof	96.4 m ²
Window area	21.7 m ²
Internal walls	225.3 m ²
Internal floor	96.4 m ²

Table 7: Thermal properties of building components for different cluster configurations.

	Heavy configuration (H)	Light configuration (L)
Structural core	Concrete	Laminated timber
Thermal transmittance U-value [W/m ² K]	0.22	0.22
Thermal mass per surface area [kg/m ²]	489	131
Periodic thermal transmittance Y _{ie} [W/m ² K]	0.014	0.068

In each configuration, the cluster was composed of four residential detached buildings with four different stochastic occupant behaviour, connected to a district heating system that allowed thermal energy exchange between buildings.

5.3 Flexibility assessment

Energy flexibility can be calculated as the measure of the cluster reaction to external forcing factors (Grønborg Junker et al., 2018). In other words, the flexibility is the difference in terms of net energy use, between the cluster managed by a control system that is not aware of the forcing factor (reference operation), and the control adapted according to the forcing factor (smart operation). In the present work, the availability of local RES production from a PV system was settled as forcing factor. For the heating period (January-April and October-December), two different temperature set-point controllers of the heating system were defined (an example is illustrated in Figure 10a-b and Figure 11a-b):

- for the reference operation (R) of the heavy weight (H) and of the light weight (L) clusters, a set-point of 20 °C was set during the day (7AM-11PM) according to the standard EN15251 (CEN, 2007), while a set-point of 16 °C was fixed for the night hours (11PM-7AM).
- for the smart operation (S) of the heavy weight (H) and of the light weight (L) clusters, a forcing factor-aware controller was designed based on the monthly available RES produced by the PV system. First, a forcing factor signal was defined: for each month of the heating period, the minimum and maximum values of the renewable energy produced were sorted; these two values were respectively associated to the upper limit of the forcing factor signal of +2 °C (intervals with high renewable production) and to the lower limit of the signal of -2 °C (intervals with low renewable production). The limits of comfortable conditions of 20 °C ±2 °C were chosen. Then, in order to define a proper signal for controlling the building set-point temperature



according to the PV production, we subdivided the range between the minimum and maximum production in nine intermediate intervals. Each interval indicates a variation of the set-point of $\pm 0.5^\circ\text{C}$ respect to the adjacent intervals.

In this study, the focus is on the aspect of energy flexibility only for what concern the use of renewables. The Flexibility Index expresses the effectiveness of the control strategy in reducing the residual demand (i.e. the fraction of the original demand not covered by in situ RES) is expressed as:

$$FI_{\text{RENEWABLES}} = \frac{\frac{Q_{\text{match}}^{\text{REF}}}{Q_{\text{consumed}}^{\text{REF}}}}{\frac{Q_{\text{match}}^{\text{SMART}}}{Q_{\text{consumed}}^{\text{SMART}}}} \quad (6)$$

$Q_{\text{match}}^{\text{REF}}$ and $Q_{\text{match}}^{\text{SMART}}$ represent the residual demand of the reference and of the smart cluster, respectively and $Q_{\text{consumed}}^{\text{REF}}$ and $Q_{\text{consumed}}^{\text{SMART}}$ express the heating demand for the reference and for the smart cluster, respectively.

For the heating period, the residual demand of the clusters $Q_{\text{match}}^{\text{REF}}$ and $Q_{\text{match}}^{\text{SMART}}$ were respectively calculated as the maximum value between 0 and the difference between the heating demand of the cluster and the renewable energy produced:

$$Q_{\text{match}}^{\text{REF}} = \int \max(0, q_{\text{consumed}}^{\text{REF}} - q_{\text{produced}}^{\text{REF}}) dt \quad (7)$$

$$Q_{\text{match}}^{\text{SMART}} = \int \max(0, q_{\text{consumed}}^{\text{SMART}} - q_{\text{produced}}^{\text{SMART}}) dt \quad (8)$$

All the terms under the integrals are expressed as power (i.e. in kW).

Thus, the residual demand refers to the energy demand not covered by RES and must therefore be satisfied with non-renewable energy sources.

In the next section, the results obtained from the simulations for the energy and flexibility performance of the clusters are presented and discussed.

5.4 Results and discussion

Energy performance

In Figure 9, the monthly heating demand values of the heavy H (top) and light L (bottom) cluster configurations are reported:

- the grey bars show the total heating demand of the cluster during reference operation (R), i.e. the energy performance of the cluster before considering the contribution of the PV production and without the smart control;
- the dashed bars show the residual demand of the cluster during reference operation (R), i.e. the energy savings of the cluster considering the contribution of the PV production (without smart control);
- the black bars show the total heating demand of the cluster during smart operation (S), i.e. the energy performance of the cluster considering only the contribution of the smart control;
- the green bars (for the heavy H cluster configuration) and the blue bars (for the light L cluster configuration) show the residual demand of the cluster during smart operation (S), i.e. the energy savings of the cluster considering both the contribution of the PV production and the smart control affecting the timing operation of the heat pump.



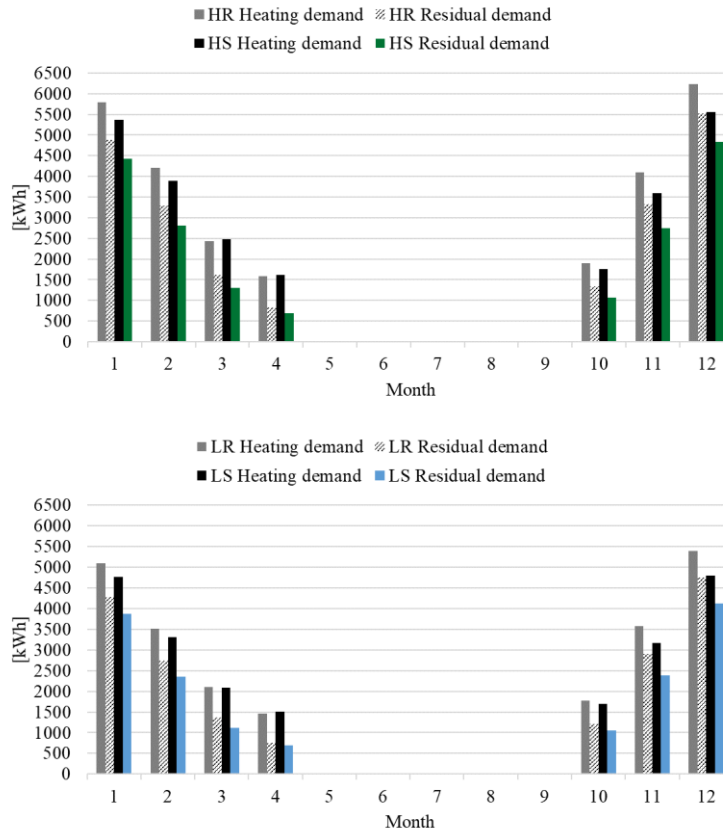

Figure 9: Monthly heating demand of the heavy weight (H) (top) and light weight (L) (bottom) simulated cluster configurations. Reference case (R) versus smart case (S).

The values of the residual demand of the simulated configurations (Q_{match}^{REF} and Q_{match}^{SMART}) were calculated as shown in Equation 7 and Equation 8. For the whole heating period, it is visible that both the PV system and the smart control contributions resulted in significant energy savings. Considering the yearly energy demand in Figure 10, for the heavy reference H cluster the PV production enabled a decrease of energy demand of 21% (20804 kWh) compared to the reference heating demand (26262 kWh), while for the heavy smart S cluster the PV production enabled a decrease of energy demand of 26% (17865 kWh) compared to the smart heating demand (24263 kWh). For the light reference L cluster the PV production enabled a decrease of energy demand of 21% (18023 kWh) compared to the reference heating demand (22900 kWh), while for the light smart S cluster the PV production enabled a decrease of energy demand of 26% (15600 kWh) compared to the light smart heating demand (21338 kWh).

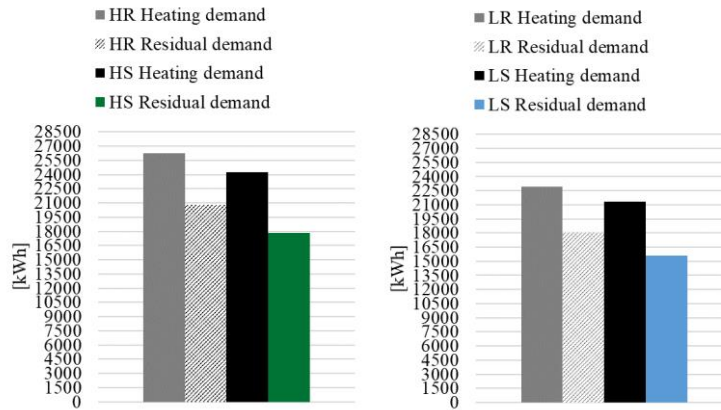

Figure 10: Yearly heating demand of the heavy weight (H) (left) and light weight (L) (right) simulated cluster configurations. Reference case (R) versus smart case (S).

The daily trends for two representative days of January and March are respectively presented in Figure 11 and Figure 12. Figure 11a and Figure 12a report the variation of the smart set-points (red lines) compared to the reference set-points (black dashed). Figure 11b and Figure 12b show in grey bars the forcing factor signal based on available renewable energy produced by the PV system. Figure 11c and Figure 12c report the indoor temperature trends for one representative building of the cluster for both heavy (H) and light (L) configurations, during reference (R) and smart (S) operation. It is visible that during unoccupied periods in which the heating system was switched off, the heavy weight building cooled down more rapidly than the light weight building, since the control was not able to fully activate the thermal mass. Figure 11d-e and Figure 12d-e present the heating demand of the reference (black dashed line) and smart configuration (green line for the heavy cluster and blue line for the light cluster) and the trend of the PV production (grey dotted line). What the smart control tried to do was to decrease the heating demand during periods of null PV production and shift/increase it during periods of available renewable energy. During the representative day of January (Figure 11d-e), it is visible that it was not possible to completely shift the smart heating demand curve in correspondence to the PV production curve, because the PV started to produce at around 9 AM but the heating system had to be turned on at 7 AM to ensure comfort conditions, both in reference and smart operation. Anyway, the smart control positively contributed to decrease the energy demand during periods of absence of renewable production and increase it during periods of available renewable production for both the heavy and the light configurations. During the representative day of March (Figure 12d-e), the PV system started in advance to produce renewable energy (7 AM) and thus it is visible a better correspondence with the trend of the heating demand. Here again, the smart control lowered the demand during periods without renewable energy production and tried to shift it during periods of available renewable energy for both the heavy and light configurations.

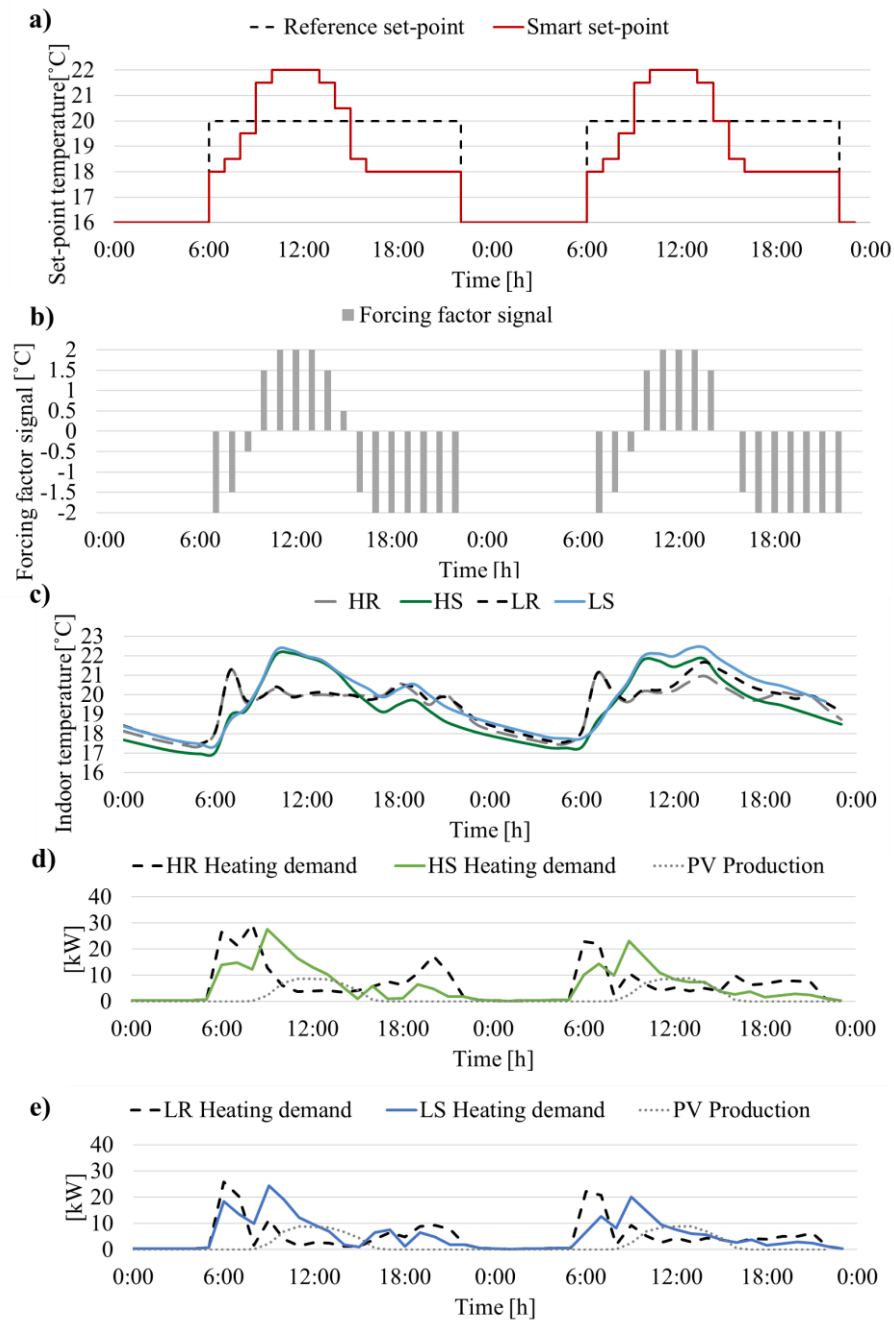

Figure 11: Daily trends for two representative days in January. a) Temperature set-point of reference and smart operation; b) Forcing factor signal; c) Indoor temperature of one representative building of the cluster for both heavy weight (H) and light weight (L) configurations, during reference (R) and smart (S) operation; d) Heating demand of the simulated heavy weight (H) configurations (reference case (R) versus smart case (S)) and PV production profile; e) Heating demand of the simulated light weight (L) configurations (reference case (R) versus smart case (S)) and PV production profile.

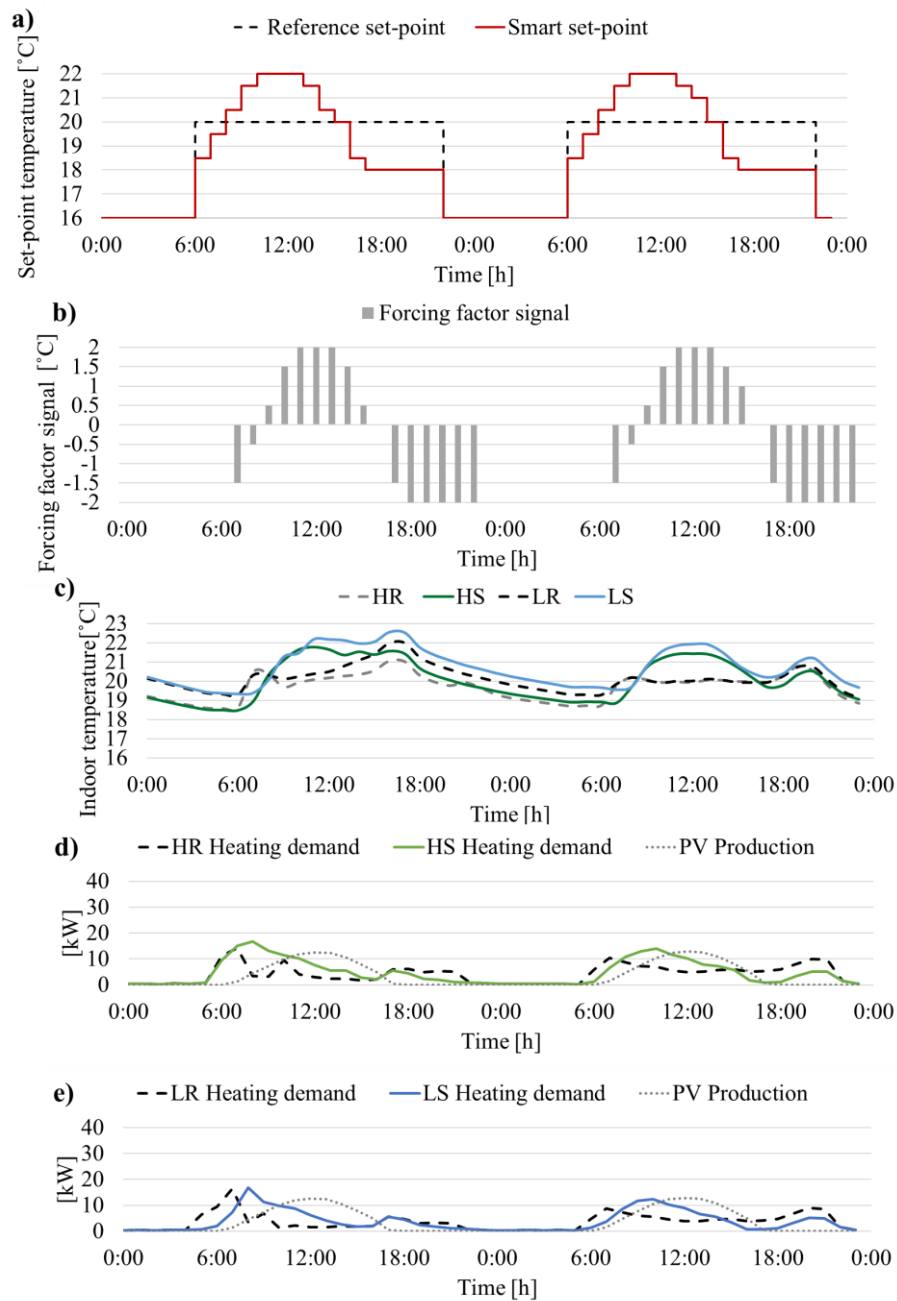

Figure 12: Daily trends for two representative days in March. a) Temperature set-point during reference and smart operation; b) Forcing factor signal; c) Indoor temperature of one representative building of the cluster for both heavy weight (H) and light weight (L) configurations, during reference (R) and smart (S) operation; d) Heating demand of the simulated heavy weight (H) configurations (reference case (R) versus smart case (S) and PV production profile; e) Heating demand of the simulated light weight (L) configurations (reference case (R) versus smart case (S) and PV production profile.

Flexibility performance

The values of the Flexibility Index $FI_{RENEWABLES}$ of the two configurations, calculated as reported in Equation 6, are shown in Figure 13 and Figure 14. From the monthly results, it is visible that in the cold months of January, February, November and December, the light cluster was slightly more flexible than the heavy cluster. On the contrary, during the warmer months of March, April and October the $FI_{RENEWABLES}$ for the heavy cluster was higher than for the light cluster; however, the residual demand was quite low in these months, so the energy saving was limited. This means that in this case, the higher thermal mass did not increase the flexibility index of the building, because as stated above, the heavy building cooled down more during unoccupied hours and the control could not fully activate the thermal mass. On the contrary, in a warm climate, a high thermal mass is expected to be advantageous, that is to increase the flexibility index. Therefore, on annual basis, the $FI_{RENEWABLES}$ value obtained by both cluster was the same (1.07). The smart control strategy achieved 7% gain in its ability to reduce electric demand using onsite renewable energy.

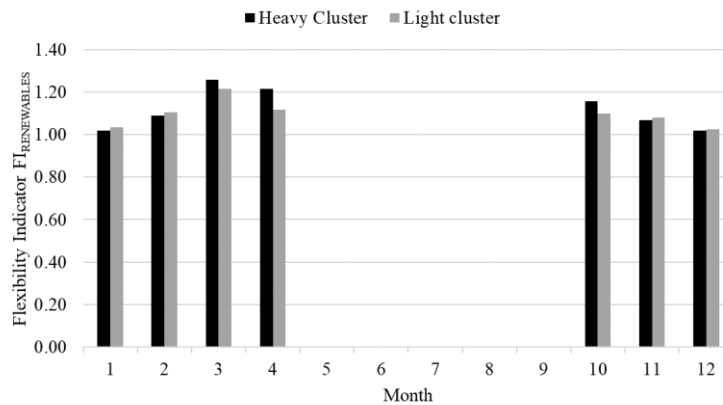

Figure 13: Monthly values of the Flexibility Index $FI_{RENEWABLES}$ for the simulated cluster configurations.

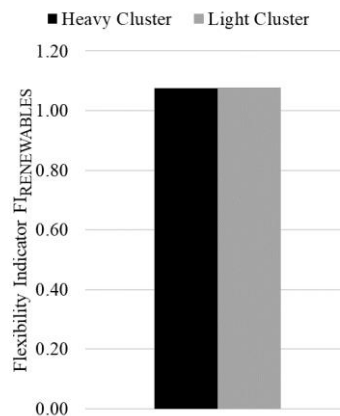

Figure 14: Yearly values of the Flexibility Index $FI_{RENEWABLES}$ for the simulated cluster configurations.

6. Conclusions

The ongoing energy system shift —from traditional centralized fossil fuel based to decentralized renewable energy sources based— challenges the stability of both electric and thermal grids and requires a strengthened control of energy matching. As part of the solution, the concept of energy flexibility introduced will allow for demand and generation management according to local climate conditions, user needs and grid requirements.



Smart buildings represent the latest step in building energy evolution and perform as active participants in the cluster/energy infrastructure scale, becoming interconnected active players that manage the energy flows. Energy planning at the building cluster scale can effectively contribute to consider the mutual connections between the buildings and energy infrastructure, in order to maximize the distributed RES harvesting and reduce carbon energy supply. The focus on cluster scale enables both to describe the synergy between buildings and energy grid (unlike the single building) while keeping track of the detailed technological building related aspects (unlike the city scale).

Nevertheless, the complex nature of the building cluster imposes the need for multi-domains modelling tools. Modelica was identified as the proper holistic modelling language for the cluster scale since several libraries have been developed to enable the sharing/exchange of energy between interconnected buildings and thermal and electrical networks within a single model and it was possible to model a building cluster considering the proper detail related to both the two scales of project, from technological component and building envelope for single building to district plants and layouts at cluster scale.

The objective of this task was the development of a modelling environment for building cluster simulation, pursued to analyze the energy performance and the flexibility potential of the cluster, taking into account the interaction between buildings, local renewable energy sources production and grid requirements.

A cluster-tailored modelling strategy implemented in Modelica language was developed, aimed at integrating both building characteristics, RES availability and energy infrastructure features. A first simplified cluster simulation test bed was carried out in Dymola environment. The resulting cluster energy demand profiles were used as input for the optimization of a PV system using EnergyMatching tool developed in Task 2.2, and the impact of building composition and use both on energy demand and energy matching with local PV production was assessed.

A second improved thermodynamic model of the cluster using the IDEAS library components was then developed with a numerical evaluation of energy flexibility of a cluster of buildings and introduce a control strategy to actively correlate the energy demand with the RES availability.

The geometrical characteristics of the buildings used for the cluster simulations are based on building stock typologies presented in TABULA projects and the results obtained from the simulations can positively be included in the repository of the EnergyMatchinghub as examples of district archetypes performances for Italian geoclusters.

Further developments and improvements of the current cluster model version will be performed on future studies in terms of components implementation and automation of the process of building design and simulation.



7. References

- Achterbosch, G. G. J. et al. (1985). The development of a convenient thermal dynamic building model. *Energy and Buildings*, 8(3), 183–196.
- Ahmed, K. et al. (2017). Occupancy schedules for energy simulation in new prEN16798-1 and ISO/FDIS 17772-1 standards. *Sustainable Cities and Society*, 35(January), 134–144.
- Ahmadi, M., Rosenberg, J. M., Lee, W.-J., & Kulvanitchaiyanunt, A. (2015). Optimizing load control in a collaborative residential microgrid environment. *IEEE Transactions on Smart Grid*, 6(3), 1196–1207.
- Ala-juusela, M., & Sepponen, T. (2014). Defining the concept of an Energy Positive Neighbourhood and related KPIs. *Sustainable places Conference*, Nice.
- Allegrini, J. et al. (2015). A review of modelling approaches and tools for the simulation of district-scale energy systems. *Renewable and Sustainable Energy Reviews*, 52, 1391–1404.
- Baetens, R. et al. (2015). Openideas – an Open Framework for Integrated District Energy Simulations. In *Proceedings of BS2015*, Hyderabad.
- Belk, R. (2010). Sharing. *Journal of Consumer Research*, 36(5), 715–734.
- Burhenne, S. et al. (2013). Building performance simulation using Modelica: analysis of the current state and application areas. *BS2013 Conference*, Chambéry.
- Carr, S. (2011). Virtual power plants. *International Journal of Scientific & Engineering Research*, 2(8), 1–4.
- CEN (2007). Indoor environmental input parameters for design and assessment of energy performance of buildings addressing indoor air quality, thermal environment, lighting and acoustics (EN 15251).
- Corrado, V. et al. (2011). *TABULA - Typology Approach for Building Stock Energy Assessment: Building Typology Brochure – Italy*.
- D’Angiolella, R., De Groote, M., & Fabbri, M. (2016). NZEB 2.0: interactive players in an evolving energy system. *REHVA Journal*, 52–55.
- Darivianakis, G., Georghiou, A., Smith, R. S., Lygeros, J. (2015). A stochastic optimization approach to cooperative building energy management via an energy hub. *IEEE CDC Conference*, Osaka.
- Dai, R., Hu, M., Yang, D., & Chen, Y. (2015). A collaborative operation decision model for distributed building clusters. *Energy*, 84, 759–773.
- De Coninck, R., Helsen, L. (2013). Bottom-up quantification of the flexibility potential of buildings. *BS2013 Conference*, Chambéry.
- Decreto del Ministero dello Sviluppo Economico (2015). Applicazione delle metodologie di calcolo delle prestazioni energetiche e definizione delle prescrizioni e dei requisiti minimi degli edifici (D.M. 26.06.2015).
- De Groote, M., Volt, J., & Bean, F. (2017). Is Europe ready for the smart buildings revolution? Mapping smart-readiness and innovative case studies.
- De Jaeger, I, Reynders, G., Ma, Y., Saelens, D. (2018). Impact of building geometry description within district energy simulations. *Energy*, 158, 1060-1069.
- EC (2016a). *Clean Energy for All Europeans*. COM(2016) 860 final. Brussels, 30.11.2016.
- EC (2016b). *Proposal for a Directive of the European Parliament and of the Council on common rules for the internal market in electricity (recast)*. COM(2016) 864 final.
- Elmqvist, H., & Mattsson, S. E. (1997). Modelica — the Next Generation Modeling Language an International



- Design Effort. *World Congress on System Simulation*, Singapore.
- Elsheikh, A., Widl, E., & Palensky, P. (2012). Simulating complex energy systems with Modelica: A primary evaluation. *IEEE International DEST Conference*, Campione d'Italia.
- Fraisse, G. et al. (2002). Development of a simplified and accurate building model based on electrical analogy. *Energy and Buildings*, 34(10), 1017–1031.
- Fritzson, P. (2004). Principles of Object-Oriented Modeling and Simulation with Modelica 2.1., Wiley-IEEE Press.
- Geidl, M., Koepfel, G., Klockl, B., Andersson, G., & Frohlich, K. (2007). Energy Hubs for the futures. *IEEE Power & Energy Magazine*, 5(1), 24–30.
- Grønberg Junker, R., Ghasem Azar, A., Amaral Lopes, R., Byskov Lindberg, K., Reynders, G., Relan, R., Madsen, H. (2018). Characterizing the energy flexibility of buildings and districts. *Applied Energy*, 225, 175–182.
- He, X. et al. (2015). Simplified Model of HVAC Load Prediction for Urban Building Districts. *Procedia Engineering*, 121, 167–174.
- Jafari-marandi, R., Hu, M., & Omitaomu, O. A. (2016). A distributed decision framework for building clusters with different heterogeneity settings. *Applied Energy*, 165, 393–404.
- Jorissen, F., Reynders, G., Baetens, R., Picard, D. Saelens, D., Helsen, L. (2018). Implementation and Verification of the IDEAS Building Energy Simulation Library. *Journal of Building Performance Simulation*, 11 (6), 669-688.
- Kämpf, J. H., & Robinson, D. (2007). A simplified thermal model to support analysis of urban resource flows. *Energy and Buildings*, 39(4), 445–453.
- Lauster, M. et al. (2014). Low order thermal network models for dynamic simulations of buildings on city district scale. *Building and Environment*, 73, 223–231.
- Lauster, M. et al. (2015). Adaptive thermal building models and methods for scalable simulations of multiple buildings using modelica. *IBPSA2015 Conference*, 339–346.
- Le Dréau, J., & Heiselberg, P. (2016). Energy flexibility of residential buildings using short term heat storage in the thermal mass. *Energy*, 111, 991–1002.
- Lovati, M., Salvalai, G., Fratus, G., Maturi, L., Albatici, R., Moser, D. (2018). New method for the early design of BiPV with electric storage: a case study in northern Italy. *Sustainable Cities and Society*. In press.
- Ma, L., Liu, N., Wang, L., Zhang, J., Lei, J., Zeng, Z., Cheng, M. (2016). Multi-party energy management for smart building cluster with PV systems using automatic demand response. *Energy and Buildings*, 121, 11–21.
- Marique, A.-F., & Reiter, S. (2014). A simplified framework to assess the feasibility of zero-energy at the neighbourhood/community scale. *Energy and Buildings*, 82, 114–122.
- Marique, A., Penders, M., Reiter, S. (2013). From zero energy building to zero energy neighbourhood. urban form and mobility matter. *PLEA2013 Conference*, Munich.
- Maturi, L., Belluardo, G., Moser, D., Del Buono, M. (2013). BiPV system performance and efficiency drops: overview on PV module temperature conditions of different module types. *SHC2013 Conference*, Freiburg.
- Müller, D. et al. (2016). AixLib – An open-source Modelica library within the IEA-EBC Annex 60 framework. *CESBP/BauSIM 2016*, Dresden.
- Nielsen, T. R. (2005). Simple tool to evaluate energy demand and indoor environment in the early stages of building design. *Solar Energy*, 78(1), 73–83.



- Orehounig, K., Mavromatidis, G., Evins, R., Dorer, V., & Carmeliet, J. (2014). Towards an energy sustainable community: An energy system analysis for a village in Switzerland. *Energy & Buildings*, 84, 277–286.
- Piacentino, A., & Barbaro, C. (2013). A comprehensive tool for efficient design and operation of polygeneration-based energy grids serving a cluster of buildings. Part II: Analysis of the applicative potential. *Applied Energy*, 111, 1222–1238.
- Ramallo-González, A. P., Eames, M. E., & Coley, D. A. (2013). Lumped parameter models for building thermal modelling: An analytic approach to simplifying complex multi-layered constructions. *Energy and Buildings*, 60, 174–184.
- Remmen, P., Lauster, M., Mans, M., Fuchs, M., Osterhage, T., Müller, D. (2018). TEASER: an open tool for urban energy modelling of building stocks. *Journal of Building Performance Simulation*, 11(1), 84–98.
- Reynders, G. (2015). Quantifying the impact of building design on the potential of structural storage for active demand response in residential buildings. KU Leuven.
- Reynders, G., Diriken, J., & Saelens, D. (2014). Quality of grey-box models and identified parameters as function of the accuracy of input and observation signals. *Energy and Buildings*, 82, 263–274.
- Shen, L., & Sun, Y. (2016). Performance comparisons of two system sizing approaches for net zero energy building clusters under uncertainties. *Energy & Buildings*, 127, 10–21.
- UNI/TS 11300-1 (2014).
- Van der Heijde, B., Aertgeerts, A., Helsen, L. (2017). Modelling steady-state thermal behaviour of double thermal network pipes. *International Journal of Thermal Sciences*, 117, 316–327.
- Van Roy, J., Verbruggen, B., & Driesen, J. (2013). Ideas for tomorrow: New tools for integrated building and district modeling. *IEEE Power and Energy Magazine*, 11(5), 75–81.
- Vigna, I. et al. (2018). New domain for promoting energy efficiency: Energy Flexible Building Cluster. *Sustainable Cities and Society*, 38, 526–533.
- Vigna, I. Perneti, R., Lovati, M. (2018b). A modelling approach for maximizing energy matching at building cluster and district scale. Proceedings from. *BSO Conference*, Cambridge.
- Voss, K., Sartori, I., Napolitano, A., Geier, S., Gonzalves, H., Hall, M., Heiselberg, P. (2010). Load matching and grid interaction of net zero energy buildings. *EuroSun Conference*, Graz.
- Wetter, M. (2009). A Modelica-Based Model Library for Building Energy and Control Systems. *BS2009*, Glasgow.



Technical references



Disclaimer

This project has received funding from the European Union's Horizon 2020 research and innovation programme under grant agreement No 768766. The sole responsibility for the content of this report lies with the authors. It does not necessarily reflect the opinion of the European Union. Neither INEA nor the European Commission are responsible for any use that may be made of the information contained therein.

While this publication has been prepared with care, the authors and their employers provide no warranty with regards to the content and shall not be liable for any direct, incidental or consequential damages that may result from the use of the information or the data contained therein. Reproduction is authorised providing the material is unabridged and the source is acknowledged



